

# Innovative Design and Implementation of an Indigenous Low Cost Cloud Based Temperature and Humidity Data Acquisition System for Atmospheric Research

Obi Nnamdi Johnpaul\*, Omeje Felix Nnaemeka, Okala Paul Arome, Ogbole Collins Iduh, Orujuba Godson Chidozie, Nwosu Izunna Onyemaechi

Department of Instrumentation, National Space Research and Development Agency -Center for Basic Space Science and Astronomy (CBSSA), Nigeria

Email: [nnamdiobi247@gmail.com](mailto:nnamdiobi247@gmail.com)\*

## ARTICLE INFO

### Article history:

Received 22 May 2026  
Accepted 04 June 2026  
Available online 07 June 2026

### Keywords:

Microcontroller ESP8266 SHT21 Accuracy Precision, Environmental Monitoring, Data Logger System, Arduino Microcontroller, Temperature and Humidity Sensing, Real-Time IoT Monitoring

### Indexed in:



and in major libraries

## ABSTRACT

The environmental monitoring or detecting device which is a data logger can be used to extract information on the temperature and the humidity of certain vicinity or area which is a very paramount criteria or yard stick to ascertain the atmospheric condition of a particular geographic location in real time anywhere globally. This distinctive device is made up of different hardware accessories interfaced appropriately together to achieve the best result in terms of accuracy and precision. Since this unique device is utilized for precise and accurate temperature and humidity readings, the electronic components used (active and passive) were meticulously selected for optimal performance. A programmable Micro controller board and a Micro controller unit is needed to work in synergy with other peripherals to achieve desirable results. We utilized the Arduino microcontroller board or its clones as it is the proposed and recommended microcontroller suitable for optimal performance of the data logging system. We also incorporated the ATMEGA328p (dual in line package version) as our micro controller unit/chip. This display unit consists of a 20\*4 (80 digits) 7 segment LCD display module (Hitachi HD 44780) compatibles or drivers and an OLED Display connection. The objectives of interfacing a dual display system are to extend the visualization of data display in real time to our extended environmental monitoring section. High accuracy and precision temperature and humidity sensor unit is interfaced in this unique work to achieve very precise and accurate readings. This sensor (SHT21) is also a low power digital temperature and humidity sensor. We now finally interface a versatile low cost and a high integrated Wi-Fi micro controller chip that enables our micro controller to communicate via Wi-Fi connection and execute basic TCP/IP transmissions. The whole hardware circuitry mode of operation is determined by the software programmable codes (source codes) written to the hardware circuit connection/interface via a USB connection to a computer system or device

© 2026 International Journal of Advanced Research in Science and Technology (IJARST).

All rights reserved.

## 1 Introduction

Technological advancement, rapid evolution, modernization of systems and in-depth research in the area of atmospheric research had led to the need of more advanced astronomical equipment for frontline space research. With optimal accuracy and precision of data obtained from research equipment outstanding results can be achieved when carrying out atmospheric research and various categories of scientific experiments

The cloud based temperature and humidity monitoring device which houses the SHT21 sensor, ESP8266 Wi-Fi module and other active and passive electronic components provides real time environmental data logging and continuous instant alert via mobile applications these devices often using IOT technology and are very ideal for application such as agriculture, pharmaceuticals and research. It is also very essential in laboratories. The project design methodology is basically structured for atmospheric research. It focuses on using low cost micro

controller (Arduino) and Sensors (SHT21) for real time environmental atmospheric records often to ensure accuracy and precise results for frontline atmospheric research

Generally the work offers real time environmental monitoring by transmitting data directly to the cloud It utilizes a very low IOT connectivity. The system utilizes SHT21 sensors interfaced to Arduino Uno for fetching temperature and humidity data readings. It also incorporates a Wi-Fi module for cloud logging and connectivity

### 1.1 Brief description of temperature and humidity sensors utilized in the project

The basic sensor I and my team endorsed for this data logging equipment is the outstanding and superior SHT21 Sensor. The SHT21 is unique in the sense that it has higher accuracy, quicker respond time and a very robust I2C interface that can support multiple sensors on a single bus

It offers better long term stability; wider temperatures span and I2C address flexibility. One basic significance of the DHT21 is that it works with 3.3 V and 5.5 V making it compatible with ESP8266 and Arduino or its clones. The sensor is a cheap accessory making it distinctive for indigenous s project designs and development

### 1.2 A brief overview on the features of various variants of temperature and humidity sensors

#### 1.2.1 DHT11

The key features of DHT11 (A widely used low-cost capacitive sensor with a thermistor) for humidity and temperature measurement

#### Key specifications

- -operating voltage---(3-3.5voltsVDC)
- -Humidity range-----20-90% RH (+-5%) Accuracy
- -Temperature range---0-50 Degree centigrade

#### Limitations

- Limited accuracy
- Limited operating range

#### 1.2.2 Key features and specification of DHT 21 sensor

- Operating voltage-3.3 - 3.5 volts
- Sensor type-capacitive humidity sensor and negative temperature coefficient (NTC) Thermistor
- Temperature range-(+40 to +80degree centigrade)
- Humidity Range-(+0 - 99.9 % RH)
- Accuracy +-5 % RH
- Transmission distance-up to 20 meters

#### Key advantage over DHT11

- Offers better accuracy than the DHT11

#### 1.2.3 Key features and specification of DHT22

- RH (0-100%)
- Temperature Range (+40 to 80degree centigrade)
- Precision (+-(0.5C) temperature
- Operating voltage (3.3 -3.5) V
- Temperature accuracy (+-0.5degree centigrade)
- Humidity accuracy (+-2% - 5%)

#### SHT21

This is a high precision low powered digital temperature and humidity sensor

#### Basic features and specifications include;

- Accuracy-+-2% RH (0-100%RH) and +\_0.3 %(-40to 125C)
- Operating range-(2.1v -3-6v)
- Interface- I2C (supports 3.3 V -5V logic)

## 2 Literature review

Some data tracking, monitoring or logging equipments utilizes only the DHT11 which is interfaced to a programmable micro controller unit for short range transmission of temperature and humidity data. The basic atmospheric monitoring sensor used in the design of temperature and humidity logging device have various limitations such as low data accuracy and precision of transmitted data

RH Sowanne et al, design and development of temperature and humidity monitoring system; Agricultural science digest 39(2) :114-118(2019)

The above work design architecture and specification was a unique and well appreciated work which is limited to the fetching and displaying of environmental data as regards temperature and humidity within a limited or short range of transmission

Wi-Fi modules which enhances wider range of transmission and utilizes internet of thing (IOT) Technology was excluded therefore cloud based transmission of temperature and humidity data can not be experienced. The accuracy and precision of the above commendable work can not be commensurate to a design process that incorporates the SHT21 Sensor. In the above work the DHT11 was utilized in the design process which culminated to a lesser accurate and precise environmental data readings.

In our work the SHT21 which is more superior and outstanding than other versions of temperature and

humidity sensors was devised and implemented in our design architecture and specification.

Azhari Hasibuan et al; Design of monitoring system for temperature and humidity using DHT22 and NRF24L01; journal of physics conference series January 2023.

The above published project employs the utilization of DHT22 Sensor which is a commendable and widely used Temperature and humidity Sensor and a communication module NRF24L01 which is a reliable and outstanding data connection module. The SHT21 Sensor is more diversified and precise in terms of range of measurement and more accurate than the DHT22. In addition the SHT21 utilizes 12C interface operating between 2.1 V -3.6 V which makes it an excellent and a more preferable low power digital sensor for IOT and environmental monitoring.

Summarily the SHT21 is more excellent and superior to the other version of temperature and humidity sensors like the DHT11, DHT22, and DHT22 due to its preferable higher accuracy, faster response time and a 12C interface that can uphold multiple sensors on a single bus. For the above reason we recommend and interface the SHT21 in our design specification.

In the process of the development of this unique data acquisition device, we incorporated an outstanding Wi-Fi module to extend our transmission distance at very large extent and also to establish a communication channel with thing speak (internet of thing (IOT)) communication platform which is an open source cloud platform

### **3 Design methodology**

The hardware design methodology consists of active and passive electronic components various electronic design modules and a DC Voltage source. An outstanding programmable microcontroller board is also needed as it is necessary for the uniqueness of the project design. A prototyping board is also significant as it is required that our hardware components are connected to the prototyping board and testrunned

The microcontroller unit is the most significant tool used to drive our device circuitry depending on how the unit is programmed to perform specific assignments. It consists of a computer on chip system designed and developed for embedded system. It integrates a processor, memory and programmable input and output peripherals on a single integrated circuit. Generally, the ESP8266 module is a low cost, highly integrated Wi-Fi chip that allows microcontrollers to connect to Wi-Fi networks and perform TCP/IP connections.

The environmental data monitoring device explores the use of IOT to disseminate data information on temperature and humidity on a global scale and in real time from our noble center via a computer and smart phones therefore

eliminating the need for manual checks. This data obtained can be used to compare contrast and analyze atmospheric data variation at different location across the globe

The hardware current and voltage requirements and specifications will be discussed and analyzed subsequently as we proceed to the detailed analysis of the project design requirements and operational conditions

### **3.1 Hardware requirements**

The hardware requirements for the implementation of the project involves the programmable micro controller, the micro controller unit, SHT21 Sensor, Dual voltage regulators, Wi-Fi modules, prototyping board, passive electronic components LCD Display modules (16\*2 LCD Display module, OLED Display module) and a rectangular plastic enclosure

These hardware components are meticulously interfaced together to meet the power, current and voltage requisites for the system's sub circuitry

**3.1.1 Programmable micro controller board-** The micro controller board utilized in the project design s the Arduino micro controller board which is an open-source micro controller used for electronic projects

The Arduino microcontroller features programmable hardware and an IDE for software development. Various versions include the UNO, NANO and the MEGA. The Model of the Arduino programmable board proposed and recommended for the project design and implementation is the Arduino Uno version.

The Arduino Uno is the most popular version recommended for beginners and professionals because it features programmable inputs and outputs pins, PWM pins and analog inputs. The Arduino also features USB ports, power jack pins and ICSP Header. Programmable codes are written to the Arduino IDE and uploaded to the Micro controller board and hardware interface via a USB connection

The IDE includes sketch examples and libraries for easy interfacing or incorporation of peripherals and accessories like motors, sensors, LED, S transistors and other electronic design and development

### **3.1.2Micro controller unit/chip**

The micro controller utilized is the ATMEGA 328 P (dual in line package) which is a 8-bit AVR/RSC based micro controller with 32KB flash, 2kb SRAM, and 1KB EEPROM. It operates between 1.8 - 5.5v and features 10-bit ADC and 23 I/O pins. It has a clock speed of about 20MHZ. Basically the ATMEGA has the TQFP and the DIL versions

The micro controller unit is vastly used in robotics, automation, and ideal for developing miniature and

massive projects. We recommended approved and implemented the 28 pin (dual inline package) DIL ATMEGA 328P version that shares the same data sheet (technical specification) with the Arduino micro controller board pin configuration and specification

### 3.1.3 SHT21 Sensor

The SHT21 Sensor which is interfaced and appropriately wired to our hardware circuitry is a low powered, high precision digital temperature and humidity sensor. It uses 12C communication (default Address, 0\*40) and operates between 2.1v -3.6v which makes it ideal for mini projects IOT and environmental monitoring

#### **Basic features and specifications include;**

- Accuracy+-2%RH
- Temperature +-0.3C
- Measuring range-0-100%RH and temperature -40 degree C to +125 degree C
- Operating voltage-2.1v -3.6v
- Current requisite-100uA--- -Active current
- 80nA----idle current
- Respond time---RH Resolution-0.04%RH; Temperature Resolution-0.01 degree C
- Extra feature-features----- Digital 12C Interface with calibrated and linearized digital output
- Micro controller Comparability ----- Highly compatible with Arduino micro controller or its Clones

### 3.1.4 Dual Voltage Regulator Board

We choose the LM1173-3v dual VR Board because of the voltage requirement of the data acquisition device. We need nominal voltage of 3.3v and 5v for the various hardware peripherals incorporated in the project design specification. A dual Voltage regulator (VR) is required to separate the power requisite for different sub circuitries of the hardware components of the system.

The Lm1173.3v is a versatile adjustable 3 terminal positive voltage regulator. It is designed for easy use and requires only two external resistors to set the output voltage

#### **Key features and specifications**

- Current output--- greater than 1.5A
- Voltage range---- adjustable from 1.25v to 37v
- Load regulation--0.01% V and 0.01% current respectively
- Operating temperature-----55 to 150 degree C

The specific version of the LM117 interfaced in our design is the LM1173.3 version. It output fixed t dual output voltages of 3.3V and 5V from individual integrated circuits

#### **Basic characteristics**

- Output voltage-1.2v at 800MA (it therefore allows 5v to provide 3.3 v)
- Output current-100 UA to 1A
- Common versions includes LM117 3.3v, LM 117 1.8v, LM 117 2.5v and LM117 5v

### 3.1.5 Wi-Fi module

A Wi-Fi module is a hardware that allows micro controllers and other embedded system to establish connection to a Wi-Fi network for data transmission. These modules allow smart home appliances, Electronic gadgets and industrial sensors to send and receive data over the internet

This Wi-Fi module is utilized in our design methodology because it is a low power communication module and its power requisites is compatible with the power requirements of other hardware circuitries and is also designed for battery option operated devices and smart home utilization offering low power energy consumption

#### **Basic technical specifications**

- Operating voltage- 3V-3.6V (3.3V highly considered)
- Flash memory-supports up to 16 megabyte (mb) external memory with common modules having up to 512 kb/(megabyte) mb or 4(megabyte ) mb
- RAM - 50-160KB
- I/O- 17GPIO pins
- ADC-10 bit ADC
- Interface-IJART, SPI,12C and PWM
- Wi-Fi- 802.11 b/g/h (2.4GHz) with support for WPA/WPA2 Security WI-FI Direct (P3P) and soft -AP
- Power consumption----less than 10uA when in deep sleep mode

#### **Common pin outs configuration and mapping for Node MCU V3 (ESP8266 Variant)**

- DO-GPIO1016
- D1----GPIO (SCL)
- D2----GP104 (SDA)
- D3-----GP100(FLASH)
- D4----GP102 (LED\_BUILT-IN)
- D5----GP104 (FLASH)
- D6----GP10129MISO)
- D7----GP1013 (MOSI)
- D8----GP1015 (SS)
- SD3---SDO-Preserved for flash memory
- RX/TX----UART SERIAL

Below is a pictorial image of the ESP8266 WI-FI Module



Fig 2.The ESP8266 Wi-Fi module (node MCU Version)

### 3.1.6 Prototyping board

Prototyping boards are very important tools used in electronic design. They are utilized to build test run or modify circuitries before proceeding to a final permanent implementation. This work was designed and test runned with a prototyping board and the circuitries was properly wired and test runned before interfacing to a permanent board permanently

The project was finally printed using a copper clad board. The printed circuit board was finally embedded to our final rectangular plastic enclosure meticulously to prevent liquid and dust particles from entering the project circuits and electronic accessories

While breadboards are faster for development they show limitations with high voltage, high frequency and complicated circuitries due to unwanted higher resistance and capacitance

### 3.1.7 Passive electronic components

Passive electronic components are also called passive devices or passive elements they independent electrical power to function. They are also two terminal electric devices which includes resistors and capacitors. These devices are interfaced to our project circuit for optimal performance. Our passive components are interfaced to our hardware circuit in series in parallel or combination of both for normal current and voltage distribution to electronic devices and accessories been used for the project development. Basic electronic components with specification

- Resistors-usually used for limiting current to the LED and other components

- Pull up resistors (10kiloohm)-usually used for signal pull up at the temperature and humidity data pin
- Resistors (330ohm)- Current and voltage limiting resistors for some hardware components.
- LED-Usually used to signal status
- Crystal oscillators
- Capacitors

### 3.1.8 20\*4 (80 digits 7 segment) LCD Display Module

Most 5v projects utilizes the 16\* 2 LCD display module which are usually compatible with the Hitachi HD 44780 drivers .This modules have 16 pins interface and this module is an alpha numeric dot matrix module operating at slightly less than 5 volts

Appropriate limiting resistor is interfaced to the Module to limit the input voltage to the LCD, s (Light emitting diode) LED. The recommended value of the resistor required for voltage limitation of the displays module's LED is obtained by dividing the forward operating voltage by the operating current of the Liquid crystal display module. Resistor value for voltage limitation to the Light emitting Diode (LED) of the Liquid crystal Display (LCD) is given by;

$R=VF/I$  (Where R is the limiting resistor value, VF is the forward operating voltage of the LED and I the current passing through the LED)

The module comes with a 16 pin interface and communication within this module is parallel. The pins of the display module were carefully wired to the project circuit according to the data sheet (technical specification) of the Display module. The microcontroller has to manipulate several interface pins to be able to control the display,

The pin out of the of the LCD Module is as follows;

#### LCD Module pin configuration and interface

- Vss --- -Power pin-GRD
- VCC---Power pin-(input)-positive
- VC---Contrast adjustment pin
- RS----Register select pin
- RW---read/write
- E---- -Enable
- DBO---data pin 1
- DB1----data pin2
- DB2----data pin 3
- DB3----data pin 4
- DB4-- -data pin 5
- DB5-- -data pin 6
- DB6-- -data pin 7
- DB7---data pin 8
- A+--- (LED Power + ve)
- K\_ --- (LED power-ve)



**Fig 3** 16\*2 LCD display Module with interface pins (16 pin interface)

### 3.1.9 5 volts (10 kilohm) rotary potentiometer.

The Trim potentiometer (voltage regulator) is needed to adjust the contrast of the LCD Display module. A 10kilohm potentiometer is needed. The 5v, 10 kilo ohm trim potentiometer also known as a rotary variable resistor operates at 5v which is the nominal/operating voltage of our data logging device. The trim potentiometer is a 3 terminal adjustable resistor used to calibrate circuits by altering resistance up to 10000 ohms. They manage low power making it perfect for adjusting voltage and current of mini projects,

The 5v, 10kilohm potentiometer which shares the same operating voltage with the data logging device is interfaced to the project circuit to adjust or vary manually the voltage of the LCD,s light emitting diode (LED). The brightness or contrast of the Display module varies when manually controlled from the trim potentiometer via wiper of the potentiometer (variable resistor)

#### Basic features and specifications

- Resistance-10000 ohms (10 kilo ohm)
- Operating voltage-5vdc

Components-3 pins (it consists of 2 pins and a center pin (wiper) that rotates clockwise and anti-clockwise for varying resistance).



**Fig 4** 5V, 10kilohm rotary potentiometer

## 3.2 General hardware operating condition

Basically the cloud based data logging device is designed for broad operational durability and flexibility. It do support indoors and environmental and harsh conditions. Most environmental monitoring equipments operate within the span of -40degree C to +85degree C and 0-90%RH.

Since the temperature and humidity sensor utilized in this project is SHT21 sensor the temperature range is in the span of -40 degree C to 125 degree C and humidity span 0-100%RH, therefore offering a wider coverage than various version of temperature and humidity sensors available.

### 3.2.1 Electrical and physical conditions

Power supply - 5VDC

Water and particle resistance. The whole system is designed to be water proof and also dust resistance. The housing and enclosure is ruggedly designed to resist any external penetration of liquid and gaseous particles.

### 3.2.2 Environmental operating range

Temperature—40 degree C to 125 degree C

Relative Humidity-0-100%RH

### 3.2.3 Data management and connectivity

Network protocols-WI-FI (24 GHZ), Cellular (4G/5G/NB-IOT)

Sampling rate-data are repeated every second

### 3.2.4 Special consideration

Calibration - frequent calibration is required to maintain accuracy and precision as continuous and prolonged exposure to extreme condition can limit sensor precision and accuracy over time

Condensation-The sensor is designed for non c condensing environment because of its flexibility and range of measurement which exceeds 100%RH

## 3.3 General circuit analysis and overview

The analysis and overview focuses on identifying the key voltage nodes and ascertain the current flow between them to ensure stability of operation. The basic components are the SHT21 sensor, ESP8266, the pull up resistor (required for data integrity) and the power source (5VDC).

### 3.3.1 Key voltage nodes and connection

- ❖ Node 0--- (GND) Ground reference for all the basic components (ESP826, GND, SHT21GND, and power supply GND).

- ❖ Node 1----- (VCC - 3.3V) Main power node usually 3.3 V powering the SHT21 (Vcc) and the ESP8266 (Vin)
- ❖ Node 2----- (Data/signal node) - The connection point between the SHT21 Data pin and the ESP8266 GPIO Pin.
- ❖ A pull up Resistor (R *pull up*=4.7kilohm to 10kilohm) is generally required between node 2 and node 1 to maintain high signal integrity.

### 3.3.2 Nodal analysis and circuit behavior

Applying Kirchhoff's law (Summation of current at basic junctions = 0)

**At node 2 (data signal)**-The current flowing from the 3.3V line through the pull up resistor  $R_p$  is given as follows;

$$I_R = \frac{V_{3.3v} - V_{data}}{R_p}$$

The sensor (SHT21) acts as a variable Impedance (Z) Device switching between high Z (Idle) and sinking current (I) to the ground (transferring data)

**Logic high**----Node 2 voltage is close to 3.3V (IR is minimal)

**Logic low**-----Node 2 voltage is near 0volts (IR is maximum  $I_R = 3.3V/R_p$ )

**At node 1(power node)** (ESP8266/SHT21) --- The ESP8266 consumes approximately (70mA-170mA) during WI-FI transmission. The total current I total drawn from the supply (Vin) is;

$$I_{Total} = I_{ESP8266} + I_{SHT21} + I_{pull-up}$$

Generally it is required a 3.3v regulator or a dual voltage regulator must be utilized to keep Node 1 stable since the ESP8266 WI-FI module can draw high current spikes

### 3.3.3 Power consumption analysis

For DC operated Node minimizing current draw is essential. Nodal analysis in deep sleep mode shows;

#### Active state;

Total current (I total) =approximately 70-100mA (WI-FI Active)

#### Deep sleep state;

Total current (I total) =less than100uA as the ESP8266 shuts down most system except the real time check (RTC)

### 3.3.4 Typical component specification

#### SHT21

Operating voltage=2-1V-3-6V

Accuracy=+-2% RH and temperature=+-3%C

#### ESP8266

Operating voltage=3.3 v

#### Cloud platform

Thing speak

#### Data interface

1-wire protocol

### 3.3.5 Summary table

COMPONENTS	FUNCTION	VCC	GND	DATA/SIGNAL
SHT21	SENSOR	2.1-3.6V	GND	DATAPIN
PULL UP RESISTOR	SIGNAL STABILTY	3.3V	-	TO DATA LINE
NODE MCU	MAIN CONTROLLER	3.3V	GND	GPIO,s

Fig 5 Summary table

### 3.4 Current voltage characteristics

The current voltage characteristics of a cloud based temperature and humidity monitoring system is specifically defined by low power requirement operation

A DC or battery source is required or power is sourced or supplied from a USB Port. The data logging device operates at 3.3v -5v with varying current consumption depending on their mode

Power consumption is often higher when in non sleep mode and lower when in sleep mode.

#### 3.4.1 Current requisite

The current consumption is characterized by a very low current during standby and high during WI-FI transmission

- Active transmission-100mA during -250mA (during WI-FI data upload)
- Active (sensing)-0.5-2.5mA (sensing only)
- Idle mode-Extremely low often less than 10uA for battery powered nodes
- Average power - Approximately 0.2mAv to 0.3mA for low power arrangements

#### 3.4.2 Basic voltage requirements

- Operating voltage-3.5-5.5v
- Battery power-usually designed for 3.3v (li-ion)(R2032) or 5V USB

#### 3.4.3 Major current voltage inherent features

- Linearity- Generally basic sensors like the DH11, DH21, DHT22 and SHT30 outputs digital data.

However the internal resistance capacitive sensing elements changes resistance and capacitance due to humidity which is converted to a digital signal by an onboard micro controller unit

- Data reliability -The sensor readings can be affected by the self heating effect if the equipment or device is not designed appropriately for low power thereby resulting to accuracy variation or low accuracy.
- Voltage sensitivity - Operating below 3V is likely to affect reading accuracy and precision, while exceeding 5.5V can damage electronic circuit components.
- Power up stability -The device usually requires a waiting period of about 1 second after powering on to stabilize before taking readings.

### 3.5 Circuitry Software development suite for the hardware

A suitable programming language code is written, debugged, verified and uploaded to the entire hardware circuit via a USB from a computer system or device. The

Arduino software code was utilized to drive the data acquisition sub circuitries. The Arduino integrated development environment (IDE) which is a cross platform application written in java programming language is used for coding, compiling and uploading of programmed codes to the circuit

We utilized the Arduino Uno version of the Arduino family and clones Micro controllers which features code editors, boot loaders and libraries

### 3.6 Cloud platform and infrastructure

The data logging device makes use of IOT tools which incorporates the SHT21 and a WI-FI module interfaced to micro con roller unit t o transmit real time data to cloud platform. The things speak platform s an open source platform utilized for visualization. The infrastructures are the cloud storage, the sensor nodes, data ingestion and the web –based dashboards for alerting and visualization.

Summarily, the cloud platform and infrastructure components includes the data acquisition (sensor), edge processing (microcontroller) and the cloud platform (open source platform) which is the thing speak used for storage and analysis of data via application interface (API)

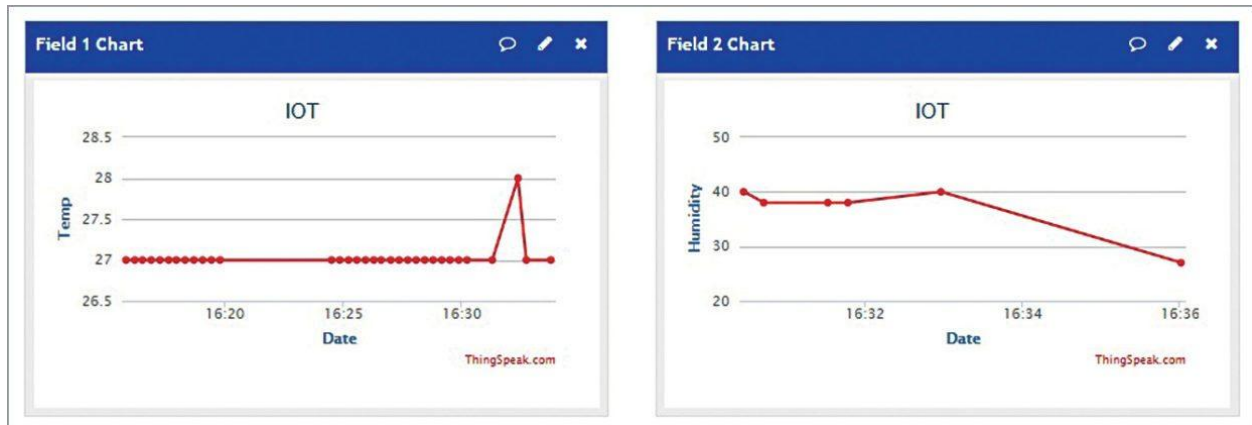

Fig 6 graphical display of temperature and humidity variation on the thing speak platform

## 4 Circuit schematic diagram of the temperature and humidity data acquisition system with key specifications and connection

The circuit design components, description and precaution is been summarized below. It analyses the active and passive electronic components implemented in our design methodology.

### 4.1 SSD1306 OLED Display Connections

OLED Pin	Function	ATmega328p Pin	Notes
VCC	Power	VCC (+5V)	<b>Note:</b> Most I2C OLEDs support 5V, but some require 3.3V - check your module's datasheet. If 3.3V is required, use a voltage regulator or level shifter.
GND	Ground	GND	Ground connection
SDA	I2C Data	PC4 (Pin 27)	Shares I2C bus with SHT21. Use 4.7kΩ pull-up to VCC (5V). Most I2C OLEDs

			are 5V-tolerant.
SCL	I2C Clock	PC5 (Pin 28)	Shares I2C bus with SHT21. Use 4.7kΩ pull-up to VCC (5V). Most I2C OLEDs are 5V-tolerant.

❖ The OLEDs offer the best picture and color depth and usually comes with a few trade offs

**PROS:**

- Stunning contrast
- Thinner and lighter
- Viewing angle: Exceptional color accuracy when viewed from extreme angles

**CONS:**

- Shorter life span
- Cost: higher manufacturing cost



**Fig 7** An OLED Display Module with Pin configuration and interface

The above diagram shows the pin mapping of the OLRD Display module .The detailed pin

Configuration is visibly seen in the above pictorial diagram.

The above OLED Display Module is the 128 \* 64 Version of the module.

**4.2 Crystal Oscillator Connection**

The crystal oscillator connection is summarized below

It includes;

- The crystal oscillator components
- The physical connection
- The required supporting circuitry

-The temperature and humidity interface

**4.2.1Crystal oscillator components**

**Crystal**

-16 MHz quartz crystal (basically HC-49S Package)

**Capacitors**

-Two 22Pf ceramic capacitors (18Pf – 22pF are widely used and acceptable)

**4.2.2 Physical connections (DIP-28 Package)**

-Crystal connection; the two leg of the 16 MHz crystal is connected to pin 9(XTAL1/PB6) and pin 10(XTAL/PB7)

-Capacitor GND: Connect one 22Pf Capacitor from pin 9 to ground

-Capacitor GND: Connect the second 22Pf Capacitor from pin 10 to GND

❖ Note - The connections is kept as close as possible to the chip to avoid noise

**4.2.3 Required supporting circuitry**

Power: VCC (pin 7 and pin 20) to +5V, GND (Pin 8 and pin 22) to GND

Reset: 10kilohm resistor between pin 1(RESET) and VCC

Decoupling: 0.1uF ceramic capacitor between VCC and GND interfaced close to the chip

**4.2.4 Temperature and Humidity Interface**

For a humidity monitoring device connect the sensor (SHT21) to any digital pin

SH21 VCC: +5V

SHT21GND: GND

LCD Display (Optional): Connect an 12C LCD to pins A4 (SDA) and A5 (SCL) to display data

**4.2.5 Trouble shooting**

Circuit wont start: Confirm the 22pF are connected securely to the ground

Ensure that the Ground pins are connected appropriately to the Ground terminals of the circuit

Ensure the Power supply pins are connected to the appropriate terminals (+5V)

Wrong baud Rate: If the serial communication is distorted, it is likely that the chip is still running on its internal clock instead of the 16 MHz crystal

**4.3 Power Connections**

VCC Pin 7 Connect to +5V regulated supply

VCC Pin 20 Connect to +5V (analog power)

GND Pins 8, Connect to ground

AREF Pin 21 Optional: external analog reference (can leave floating)

**4.4 Power Supply Requirements**

- **Operating Voltage:** 5V DC regulated
- **Current Consumption:**
  - ATmega328p: ~15 mA (active at 16MHz)
  - SHT21 sensor: ~0.3 mA (measuring)
  - OLED display: ~20 mA (typical)
  - **Total:** ~35-40 mA( typical)
- **Recommended Power Source:**
  - USB power supply (5V, 500mA)
  - Battery with 5V regulator
  - Arduino USB connection for development

**4.5 Circuit schematic Diagram of the cloud based temperature and humidity Data acquisition device**

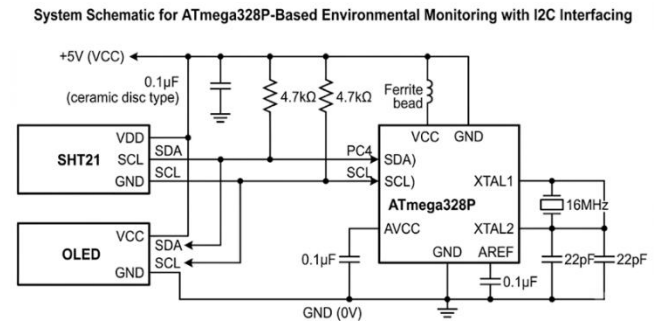

**4.6 Additional information on additional circuit requirement for optimal performance** – We still have to throw more light and elaborate on additional electronic accessories needed for optimal and smooth circuitry performance. Below are additional details on electronic requirements interfaced for optimal performance of the data acquisition device.

**4.6.1 Crystal oscillator**

The crystal oscillator plays a basic role in the data acquisition system; It is often refer to as the heart beat of the device. It provides a stable, precise and a consistent frequency source. The basic function of the crystal oscillator interfaced in the circuit is as follows;

- Provision of the fundamental clock signal for the device’s microprocessor therefore allowing it to process sensor data, run the control logic and manage the display

- Data synchronization - In IOT enabled monitoring systems like our unique cloud based monitoring device. It synchronizes communication modules making sure data is transmitted to a central server or mobile applications without any delay or error
- Sensor measurement Accuracy - The sampling rate measurement accuracy of analog to digital converter (ADC, s) responsible for reading the humidity and temperature sensors are dependent at a very large scale on the clock signal generated by the crystal.

#### 4.6.2 O-LED Display Module

With microcontrollers, A miniature high contrast display module often used for displaying text or graphics in low power electronic devices or system .The modules often use the SSD1306 driver therefore allowing 12C Communication like the widely used Arduino.

#### Key specifications and feature

- Emission characteristics-Self Emission
- Operating voltage-3.3V to 5V
- Power Consumption- Low power Consumption
- Driver IC-SSD1306
- Operating Temperature--- (0 degree C to 40 degree C)

#### 5 Pictorial view of the developed environmental data acquisition system

The pictorial view of the temperature and humidity data logging device is shown below .It presents the general and final enclosure of the hardware electronic components (active and passive components) devised in the design process and implemented of the data logging system.



**Fig 9** Pictorial view of the developed data acquisition device

#### 6 Results and discussion

The SHT21 temperature and humidity monitoring device offers more improved efficacy, safety and compliance while reducing cost and also enabling fast action of response against environmental digressions. The work emphasis on design and development of an accurate and precise atmospheric data logging device for atmospheric and environmental monitoring

While this system reading is highly accurate and precise, it has its own limitation and future outlook. While very efficient this system or device requires stable network connectivity and in some instances, further improvement in sensor calibration accuracy. Frequent improvement in the area of scientific and technological research especially in the area of IOT technology can culminate to a robust information data management system, diversification and a much deeper integration for automated environmental management

#### 7 Conclusion

The data acquisition device reduces human error and provides accurate continuous data which is significant for protecting sensitive equipment and ensuring safety standards. The outstanding device is cost effective and utilizes the ATMEGA micro controller unit or chip making it relatively inexpensive. Cloud storage also enables historical data analysis to identify trends and upgrade environmental control over time.

Conclusively, this monitoring system which is IOT integrated provides real time data and accessibility. They allow for constant remote tracking of environmental condition which can be shared globally

#### 8 Acknowledgement

We are very much indebted to the staff of instrumentation division-Center for basic science and Astronomy (CBSSA) Nsukka Nigeria for their inspiration, motivation and distinctive support that extends to my team members Collins, Chidoozie and Izunna for their enthusiasm and support that culminated to the successful completion and publication of this work

We also extend our gods will message and appreciation to the Head of division Engr Ezechi Nwachukwu and our Able and Amiable Director, Dr B.I Okere for their unpatrolled motivation and overwhelming support.

#### References

1. Badamasi, Y. A. (2014). The working principle of an Arduino. *ICECCO*, 9, 3–6.
2. Bell, C. (2021). Introducing the Arduino. In *Beginning IoT Projects* (Vol. 3, pp. 31–70). Apress, Berkeley.

3. Kate, V., & Kulkarni, R. (2016). Real time, remote temperature and humidity monitoring using Arduino and XBee S2. *International Journal of Innovative Research in Electrical, Electronics, Instrumentation and Control Engineering*, 4(6), 175–179.
4. Kunjumon, S., Pinto, K., & Saldanha, J. (2016). Temperature and humidity monitoring and alert management system. *International Journal of Engineering Research and General Science*, 4(4), 349–351.
5. Maini, A. K. (1998). *Electrical projects for beginners* (2nd ed., pp. 211–213). Pustak Mahal.
6. R. N. Sonawane, A. S. Ghuhe, A. P. Bowhekar, & A. H. Zakane. (n.d.). Design and development of temperature and humidity monitoring system. *Agricultural Science Project*, 39(2), 114–118. <https://doi.org/10.18805/ag.D-4893>
7. Sipani, J., Patel, R., & Upadhyaya, T. (2017). Temperature and humidity monitoring and control system based on Arduino and SIM900 GSM shield. *International Journal of Electrical, Electronics and Data Communication*, 5(11), 62–68.
8. AOSONG. (2010). *Temperature and humidity datasheet* (pp. 1–6).
9. Wikipedia. (n.d.). Retrieved from <http://www.wikipedia.org>
10. Instructables. (n.d.). Retrieved from <http://www.instructables.com>